

Angular Style Air Gripper

Series *MHC2/MHCA2/MHCM2*

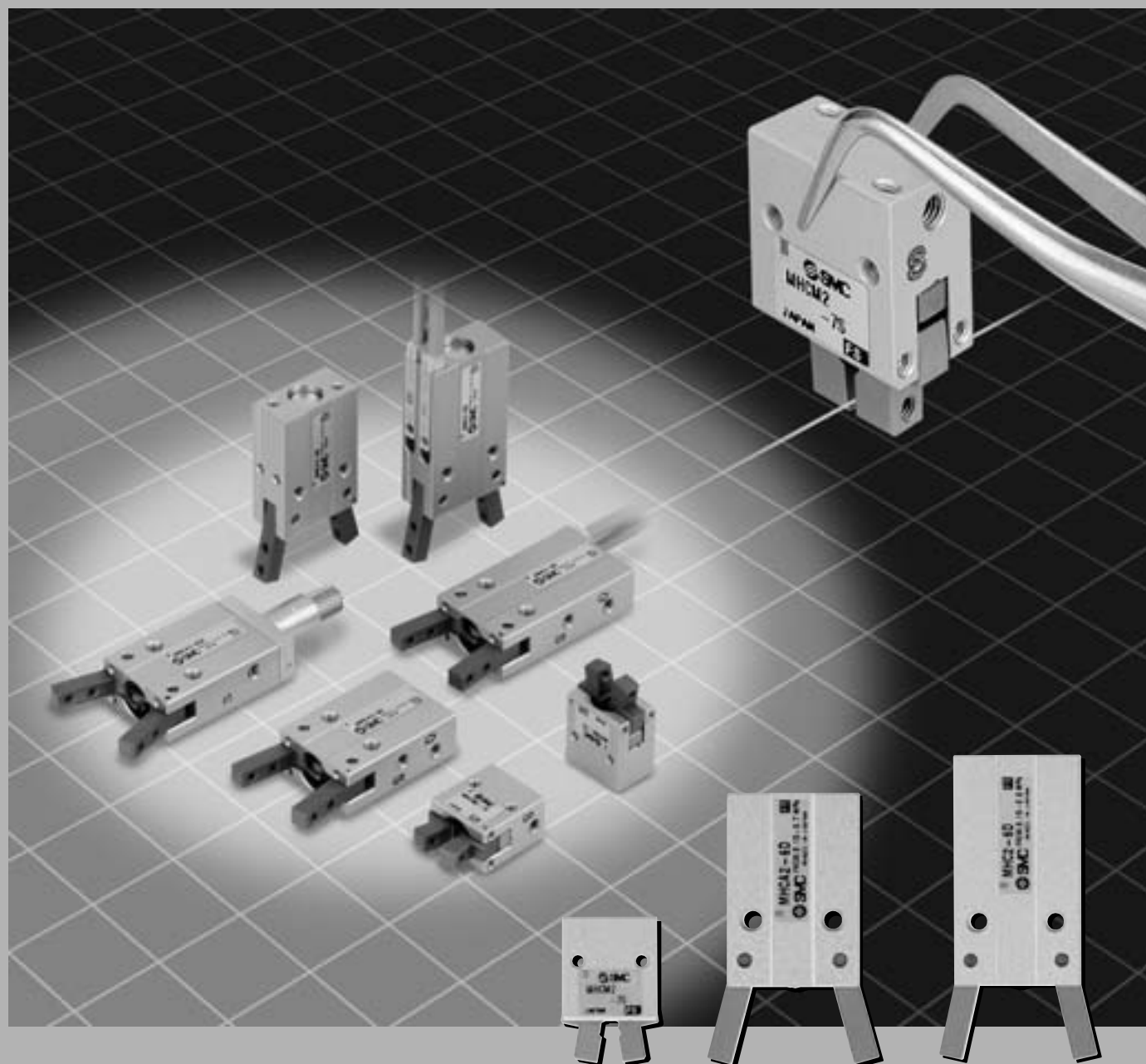

Angular style air gripper

Series MHC2/MHCA2/MHCM2

MHC2-6□

Auto switch is attachable.

48 mm x 20 mm x 10 mm 22 g

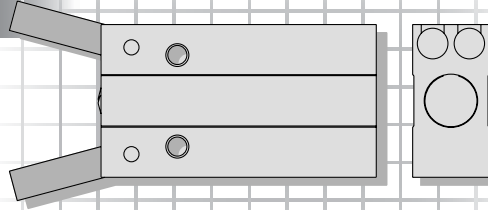

Body option (Only for MHCA2-6)

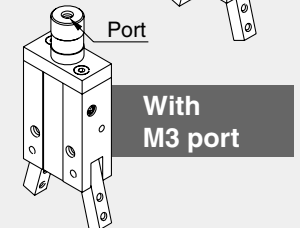
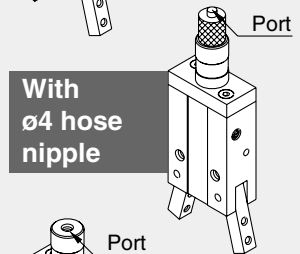
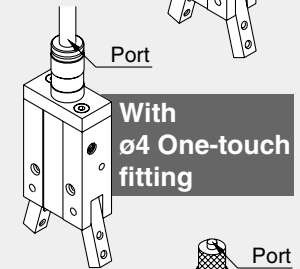
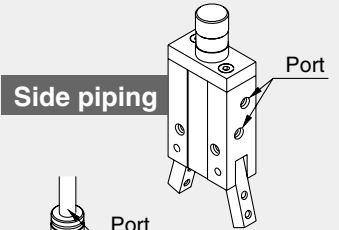

MHCA2-6□

Short body.

41 mm x 20 mm x 10 mm 19 g

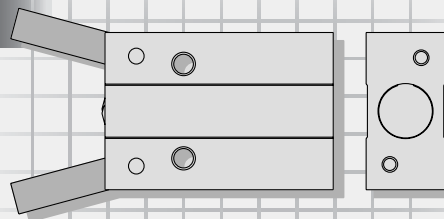

MHCM2-7S

Smallest size and lightest mass in MHC series.

23 mm x 15 mm x 10 mm 9.5 g

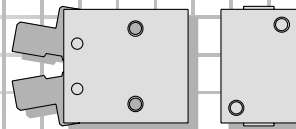

Variations



Page 622



Page 622



Page 631

Model	MHC2-6□	MHCA2-6□	MHCM2-7S
Cylinder bore	ø6	ø6	ø7
Action	Double acting Single acting (Normally open)		Single acting (Normally open)
Opening/Closing angle (Both sides)	30° to -10°		20° to -7°
Holding moment (at 0.5 MPa)	0.038 N·m (Double acting) 0.024 N·m (Single acting)		0.017 N·m
Repeat ability	±0.02 mm		
Maximum operating frequency	180 c. p.m		
Mass	22 g (Note)	19 g	9.5 g
Auto switch	Solid state auto switch (2-wire, 3-wire)	—	—
Body option	—	End boss type	—

Note) Not including auto switch mass.



Series MHC2/MHCA2/MHCM2 Specific Product Precautions

Be sure to read before handling.

Mounting

Warning

1. Tighten the screw within the specified torque range when mounting the air gripper.

Tightening with a torque above the limit can cause malfunction, while insufficient tightening can cause slippage and dropping.

How to Mount Air Grippers

Axial Mounting (Body tapped)

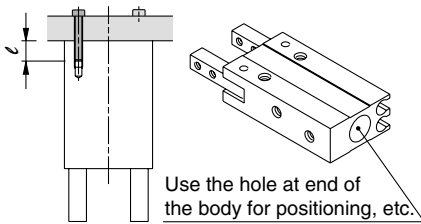

Model	Bolt	Max. tightening torque N·m	Max. screw-in depth ℓ mm
MHCA2-6	M2 x 0.4	0.15	6
MHCM2-7S	M2 x 0.4	0.15	4

Note) MHC2-6 is not compatible with axial mounting.

Model	Hole dia. mm	Hole depth mm
MHCA2-6	$\phi 7H8^{+0.022}_0$	1.5

Vertical mounting (Body tapped)

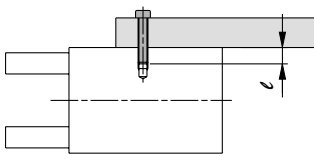

Model	Bolt	Max. tightening torque N·m	Max. screw-in depth ℓ mm
MHCA2-6	M2 x 0.4	0.15	4

Note) MHC2-6 and MHCM2-7S are not compatible with vertical mounting.

Lateral mounting (Body tapped, body through-hole)

● Body tapped

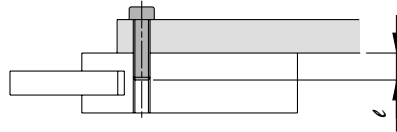

Model	Bolt	Max. tightening torque N·m	Max. screw-in depth ℓ mm
MHC2-6	M3 x 0.5	0.88	10
MHCA2-6	M3 x 0.5	0.88	10
MHCM2-7S	M2 x 0.4	0.15	10

● Body through-hole

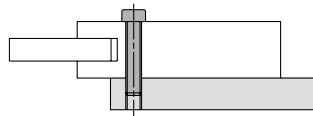

Model	Bolt	Max. tightening torque N·m
MHC2-6	M2.5 x 0.45	0.49
MHCA2-6	M2.5 x 0.45	0.49

Note) MHCM2-7S is not compatible with body through-hole mounting.

Warning

2. Do not scratch or dent the air gripper by dropping or bumping it when mounting.

Slight deformation can cause inaccuracy or a malfunction.

3. Tighten the screw within the specified torque range when mounting the attachment.

Tightening with a torque above the limit can cause malfunction, while insufficient tightening can cause slippage and dropping.

How to Mount Attachment to the Finger

Make sure to mount the attachments on fingers with the tightening torque in the table below by using bolts, etc., for the female threads on fingers.

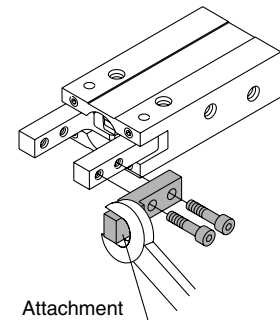

Model	Bolt	Max. tightening torque N·m
MHC□2-6	M2 x 0.4	0.15
MHCM2-7S	M2 x 0.4	0.15

MHZ

MHF

MHL

MHR

MHK

MHS

MHC

MHT

MHY

MHW

-X□

MRHQ

MA

D-□

Series MHC2/MHCA2/MHCM2 Model Selection

Model Selection

Selection Procedure

Step 1 Confirm gripping force → Step 2 Confirmation of inertial moment of attachment

Step 1 Confirmation of Gripping Force

Confirmation of conditions → Calculation of required gripping force → Model selection from gripping force graph

Example Workpiece mass: 0.01 kg

Gripping method: External gripping

Model selection criteria with respect to workpiece mass

- Although differences will exist depending on factors such as shape and the coefficient of friction between the attachments and workpieces, select a model which will provide a gripping force 10 to 20 times the (Note 1) weight of the workpiece.
- (Note 1) Refer to the model selection illustration for more information.
- Furthermore, in cases with high acceleration or impact, etc., it is necessary to allow an even greater margin of safety.

Example: When it is desired to set the gripping force at 10 times or more the workpiece weight.
Required gripping force = 0.01 kg x 10 x 9.8 m/s²
= Approx. 0.98 N or more

Length of gripping point: 25mm

Operating pressure: 0.4MPa

MHC2-6D/MHCA2-6D

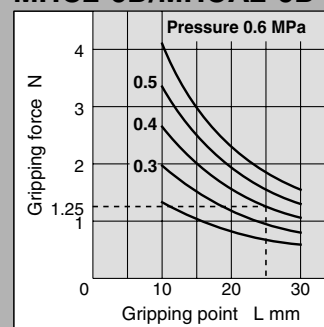

- Selecting the **MHC2-6D**. The gripping force of 1.25 N is obtained from the intersection point of gripping point distance L = 25 mm and pressure of 0.4 MPa.
- The gripping force is 12.7 times greater than the workpiece weight, and therefore satisfies a gripping force setting value of 10 times or more.

Model Selection Illustration

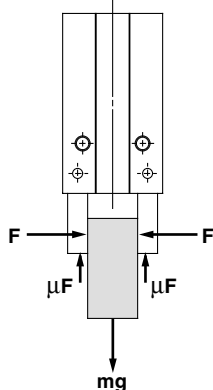

When gripping a workpiece as in the figure to the left and with the following definitions,
F: Gripping force (N)
μ: Coefficient of friction between attachments and workpiece
m: Workpiece mass (kg)
g: Gravitational acceleration (= 9.8 m/s²)
mg: Workpiece weight (N)

the conditions under which the workpiece will not drop are

$$2 \times \mu F > mg$$

Number of fingers

and therefore,

$$F > \frac{mg}{2 \times \mu}$$

With "a" as the safety margin, F is determined as follows:

$$F = \frac{mg}{2 \times \mu} \times a$$

Gripping force at least 10 to 20 times the workpiece weight

The "10 to 20 times or more of the workpiece weight" recommended by SMC is calculated with the safety margin of a = 4, which allows for impacts that occur during normal transportation, etc.

When $\mu = 0.2$	When $\mu = 0.1$
$F = \frac{mg}{2 \times 0.2} \times 4$	$F = \frac{mg}{2 \times 0.1} \times 4$
$= 10 \times mg$	$= 20 \times mg$

10 x workpiece weight

20 x workpiece weight

(Note) · Even in cases where the coefficient of friction is greater than $\mu = 0.2$, for safety reasons, SMC recommends selecting a gripping force which is at least 10 to 20 times the workpiece weight.
 · It is necessary to allow a greater safety margin for high accelerations and strong impacts, etc.

Step 1 Effective Gripping Force: Series MHC□2 External Gripping Force

- Expressing the effective gripping force
The effective gripping force shown in the graphs to the right is expressed as F, which is the thrust of one finger when both fingers and attachments are in full contact with the workpiece as shown in the figure below.

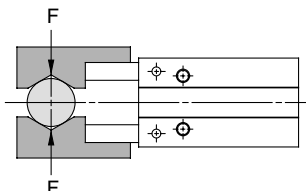

External Gripping

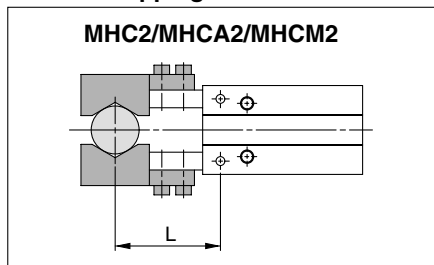

MHC2-6D/MHCA2-6D

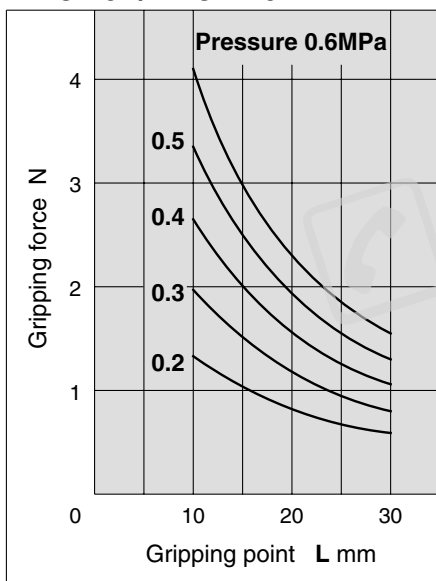

MHC2-6S/MHCA2-6S

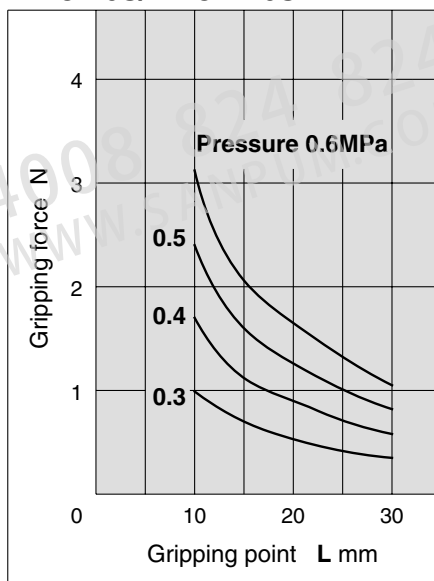

MHCM2-7S

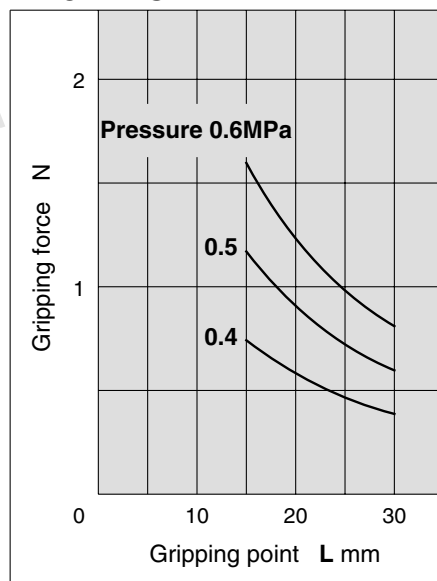

MHZ

MHF

MHL

MHR

MHK

MHS

MHC

MHT

MHY

MHW

-X□

MRHQ

MA

D-□

Series MHC2/MHCA2/MHCM2

Step 2 Confirmation of Inertial Moment of Attachment

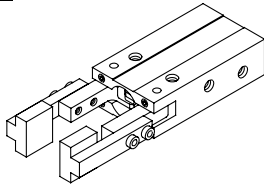

Confirm the inertial moment of one of the two attachments.
For example, in calculating the inertial moment of an attachment in the picture on the left, divide it into 2 rectangular parallelepipeds, A part and B part.

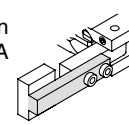

A part

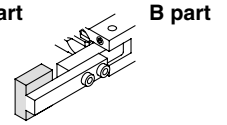

B part

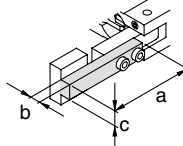
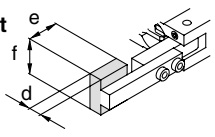
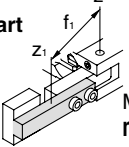
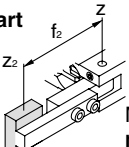
Procedure	Formula	Example						
<p>1. Calculate the operating conditions and attachment dimensions.</p>	<p>A part</p>  <p>B part</p> 	<p>Operating equipment: MHC2-6D a = 20 (mm) b = 3 (mm) c = 4 (mm) d = 4 (mm) e = 5 (mm) f = 6 (mm)</p>						
<p>2. Calculate the inertial moment of the attachment.</p>	<p>A part</p>  <p>Mass calculation $m_1 = a \times b \times c \times \text{Relative density}$ Inertial moment around Z1 axis $I_{Z1} = \{m_1 (a^2 + b^2) / 12\} \times 10^{-6}$ Inertial moment around Z axis $I_A = I_{Z1} + m_1 r_1^2 \times 10^{-6}$</p> <p>B part</p>  <p>Mass calculation $m_2 = d \times e \times f \times \text{Relative density}$ Inertial moment around Z2 axis $I_{Z2} = \{m_2 (d^2 + e^2) / 12\} \times 10^{-6}$ Inertial moment around Z axis $I_B = I_{Z2} + m_2 r_2^2 \times 10^{-6}$</p> <p>Thus, the total inertial moment is $I = I_A + I_B$ (*: Unit conversion constant)</p>	<p>Assuming the attachment material is aluminium alloy (relative density=2.7), $r_1 = 16.4$ (mm). $m_1 = 20 \times 3 \times 4 \times 2.7 \times 10^{-6}$ $= 6.48 \times 10^{-4}$ (kg) $I_{Z1} = \{6.48 \times 10^{-4} \times (20^2 + 3^2) / 12\} \times 10^{-6}$ $= 2.21 \times 10^{-8}$ (kg·m²) $I_A = 2.21 \times 10^{-8} + 6.48 \times 10^{-4} \times 16.4^2 \times 10^{-6}$ $= 0.20 \times 10^{-6}$ (kg·m²)</p> <p>$r_2 = 23.5$(mm) $m_2 = 4 \times 5 \times 6 \times 2.7 \times 10^{-6}$ $= 3.24 \times 10^{-4}$ (kg) $I_{Z2} = \{3.24 \times 10^{-4} \times (4^2 + 5^2) / 12\} \times 10^{-6}$ $= 1.11 \times 10^{-9}$ (kg·m²) $I_B = 1.11 \times 10^{-9} + 3.24 \times 10^{-4} \times 23.5^2 \times 10^{-6}$ $= 0.18 \times 10^{-6}$ (kg·m²) $I = 0.20 \times 10^{-6} + 0.18 \times 10^{-6}$ $= 0.38 \times 10^{-6}$ (kg·m²)</p>						
<p>3. Confirm from the table that the inertial moment of one attachment is within the allowable range.</p>	<p>MHC2-6D/MHCA2-6D</p> <table border="1" data-bbox="555 1635 976 1863"> <tr> <td>Finger opening and closing speed</td> <td>Allowable inertial moment of attachment</td> </tr> <tr> <td>Without speed controller</td> <td>0.5 × 10⁻⁶ Kg·m²</td> </tr> <tr> <td>With speed controller 3/4 to 1 and 1/2 reverse rotation from fully close state</td> <td>1.5 × 10⁻⁶ Kg·m²</td> </tr> </table> <p>Attachment inertial moment > Allowable inertial moment</p>	Finger opening and closing speed	Allowable inertial moment of attachment	Without speed controller	0.5 × 10 ⁻⁶ Kg·m ²	With speed controller 3/4 to 1 and 1/2 reverse rotation from fully close state	1.5 × 10 ⁻⁶ Kg·m ²	<p>Attachment inertial moment 0.38 × 10⁻⁶ (kg·m²) < Allowable inertial moment without speed controller 0.5 × 10⁻⁶ (kg·m²)</p> <p>Therefore, the attachment can be used without a speed controller.</p>
Finger opening and closing speed	Allowable inertial moment of attachment							
Without speed controller	0.5 × 10 ⁻⁶ Kg·m ²							
With speed controller 3/4 to 1 and 1/2 reverse rotation from fully close state	1.5 × 10 ⁻⁶ Kg·m ²							

Symbol

Symbol	Definition	Unit
Z	Central axis of finger rotation	—
Z1	Axis which contains center of gravity of attachment A part and is parallel to Z	—
Z2	Axis which contains center of gravity of attachment B part and is parallel to Z	—
I	Total inertial moment of attachment	kg·m ²
Iz1	Inertial moment around Z1 axis of attachment A part	kg·m ²
Iz2	Inertial moment around Z2 axis of attachment B part	kg·m ²
IA	Inertial moment around Z axis of attachment A part	kg·m ²
IB	Inertial moment around Z axis of attachment B part	kg·m ²
m1	Mass of attachment A part	kg
m2	Mass of attachment B part	kg
r1	Distance between axes Z and Z1	mm
r2	Distance between axes Z and Z2	mm

Limiting Range of Attachment Inertial Moment

MHC2-6D/MHCA2-6D

Finger opening and closing speed	Allowable inertial moment of attachment	Mass (Guide)
Without speed controller ^{Note)}	0.5 x 10 ⁻⁶ kg·m ²	2 g or less
With speed controller 3/4 to 1 and 1/2 reverse rotation from fully close state	1.5 x 10 ⁻⁶ kg·m ²	3.5 g or less

MHC2-6S/MHCA2-6S

Finger opening and closing speed	Allowable inertial moment of attachment	Mass (Guide)
Without speed controller ^{Note)}	0.5 x 10 ⁻⁶ kg·m ²	2 g or less
With speed controller 3/4 to 2 reverse rotation from fully close state	1.5 x 10 ⁻⁶ kg·m ²	3.5 g or less

MHCM2-7S

Finger opening and closing speed	Allowable inertial moment of attachment	Mass (Guide)
Without speed controller ^{Note)}	0.3 x 10 ⁻⁶ kg·m ²	2 g or less
With speed controller 1/2 to 1 3/4 reverse rotation from fully close state	1.0 x 10 ⁻⁶ kg·m ²	3.3 g or less

* Applicable speed controller ——— Air gripper direct connection type AS1211F-M3
Use a meter-in type.
Note) In the case of MHCM2-7S, provide a run off space because the speed controller protrudes from the body top surface by 0.6 mm.

Note) Sometimes the workpiece may not be gripped precisely because of excessive speed in finger opening and closing. Therefore, use a meter-in type speed controller to adjust the finger opening and closing speed.

- MHZ
- MHF
- MHL
- MHR
- MHK
- MHS
- MHC**
- MHT
- MHY
- MHW
- X□
- MRHQ
- MA
- D-□

Angular Style Air Gripper

Series MHC2-6/MHCA2-6

How to Order

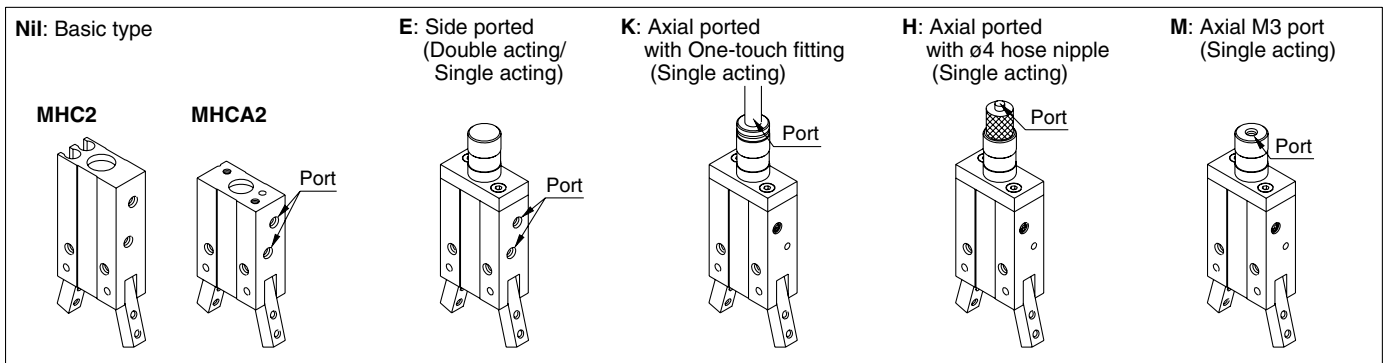
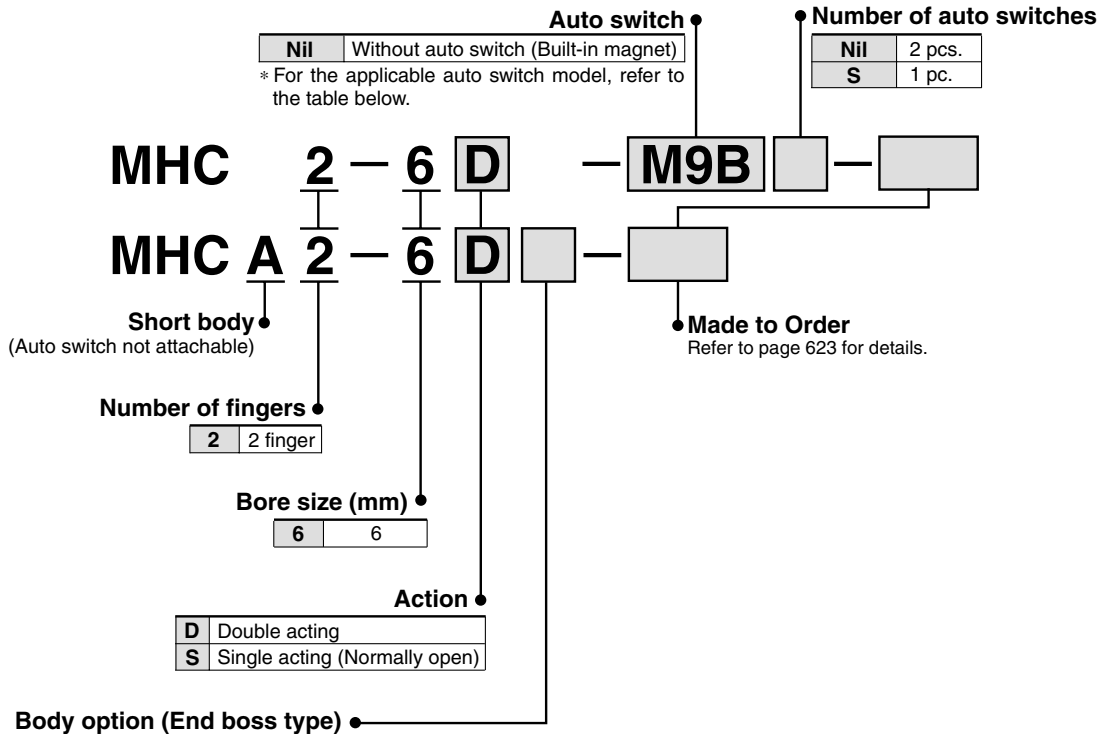

Applicable Auto Switches/Refer to pages 761 to 809 for further information on auto switches.

Type	Special function	Electrical entry	Indicator light	Wiring (Output)	Load voltage		Auto switch model		Lead wire length (m)*				Pre-wired connector	Applicable load		
					DC	AC	Perpendicular	In-line	0.5 (Nil)	1 (M)	3 (L)	5 (Z)		IC circuit	Relay, PLC	
Solid state switch	—	Grommet	Yes	3-wire (NPN)	24 V	5 V,	—	M9NV	M9N	●	●	○	○	○	—	Relay, PLC
				3-wire (PNP)		12 V		M9PV	M9P	●	●	○				
				2-wire		12 V		M9BV	M9B	●	●	○				

* Lead wire length symbols: 0.5 m Nil (Example) M9N
 1 m M (Example) M9NM
 3 m L (Example) M9NL
 5 m Z (Example) M9NZ

* Auto switches marked with "○" are made to order specification.

Angular Style Air Gripper *Series MHC2-6/MHCA2-6*



JIS Symbol
Double acting

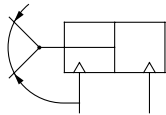

Single acting

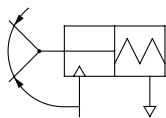

Made to Order
Refer to pages 683 to 713 for details.

Symbol	Specifications/Description
-X4	Heat resistance (100°C)
-X5	Fluororubber seal
-X53	EPDM seal/Fluorine grease
-X56	Axial piping type
-X63	Fluorine grease
-X64	Finger: Side Tapped Mounting
-X65	Finger: Through-hole mounting
-X79	Grease for food

Specifications

Fluid		Air
Operating pressure	Double acting	0.15 to 0.6 MPa
	Single acting: Normally open	0.3 to 0.6 MPa
Ambient and fluid temperature		-10 to 60°C
Repeatability		±0.02 mm
Maximum operating frequency		180 c.p.m
Lubrication		Non-lube
Action		Double acting, Single acting (Normally open)
Auto switch (Option) ^{Note)}		Solid state auto switch (3-wire, 2-wire)

Note) Refer to pages 761 to 809 for further information on auto switches.

Model

Action	Model	Cylinder bore (mm)	Gripping moment (Effective value) N·m ⁽¹⁾	Opening/Closing angle (Both sides)	Mass (g) ⁽²⁾
Double acting	MHC2-6D	6	0.038	30° to -10°	22
	MHCA2-6D	6			19
Single acting (Normally open)	MHC2-6S	6	0.024	30° to -10°	22
	MHCA2-6S	6			19

Note 1) At the pressure of 0.5 MPa

Note 2) Excluding the auto switch mass.

Option

●Body Option/End Boss Type

Symbol	Piping port location	Type of piping port	Applicable model	
		MHCA2-6	Double acting	Single acting
Nil	Basic type	M3 x 0.5	●	●
E	Side ported	M3 x 0.5	●	●
K	Axial ported	With ø4 one-touch fitting	—	●
H		With ø4 hose nipple	—	●
M		M3 x 0.5	—	●

MHZ

MHF

MHL

MHR

MHK

MHS

MHC

MHT

MHY

MHW

-X□

MRHQ

MA

D-□

Series MHC2-6/MHCA2-6

Construction

MHC2-6

Double acting/With fingers open

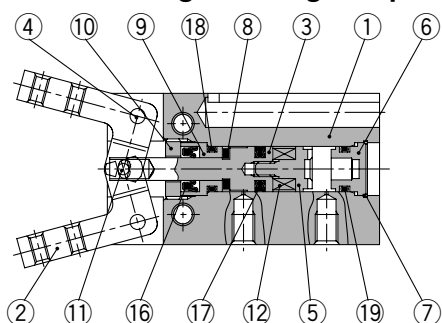

Double acting/With fingers closed Single acting

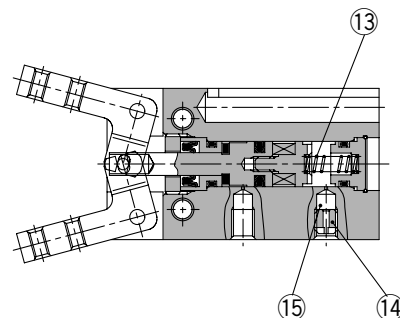
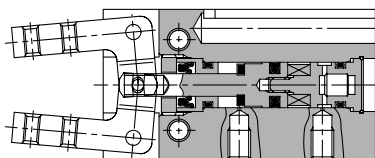

Component Parts

No.	Description	Material	Note
1	Body	Aluminium alloy	Hard anodized
2	Finger	Stainless steel	Heat treatment
3	Piston	Stainless steel	
4	Lever shaft	Stainless steel	Nitriding
5	Magnet holder	Stainless steel	
6	Cap	Aluminium alloy	Hard anodized
7	Clip	Stainless steel	
8	Bumper	Urethane rubber	
9	Holder	Brass	Electroless nickel plated
10	Holder lock	Stainless steel	

No.	Description	Material	Note
11	Needle roller	High carbon chromium bearing steel	
12	Magnet	—	Nickel plated
13	N.O. spring	Piano wire	Zinc chromated
14	Exhaust plug	Brass	Electroless nickel plated
15	Exhaust filter	Resin	
16	Rod seal	NBR	
17	Piston seal	NBR	
18	Gasket	NBR	
19	Gasket	NBR	

Replacement Parts

Description	Kit no.	Main parts	Note
Seal kit	Please contact SMC to replace seal kit		

Replacement part/Grease pack part no.: GR-S-005 (5 g)

MHCA2-6 (Short body type)

Double acting/With fingers open

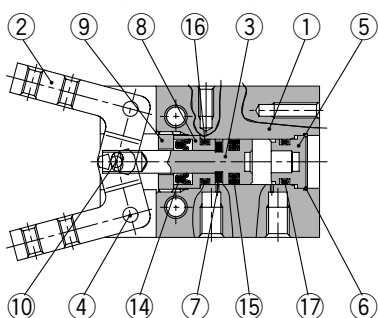

Double acting/With fingers closed Single acting

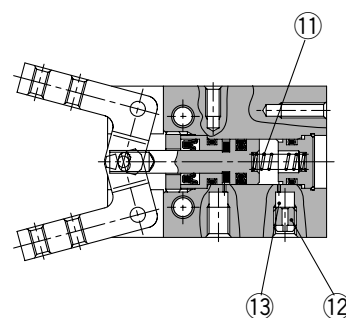
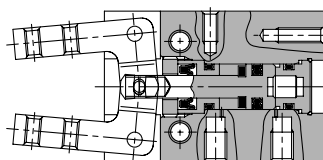

Component Parts

No.	Description	Material	Note
1	Body	Aluminium alloy	Hard anodized
2	Finger	Stainless steel	Heat treatment
3	Piston	Stainless steel	
4	Lever shaft	Stainless steel	Nitriding
5	Cap	Aluminium alloy	Hard anodized
6	Clip	Stainless steel	
7	Bumper	Urethane rubber	
8	Holder	Brass	Electroless nickel plated
9	Holder lock	Stainless steel	

No.	Description	Material	Note
10	Needle roller	High carbon chromium bearing steel	
11	N.O. spring	Piano wire	Zinc chromated
12	Exhaust plug	Brass	Electroless nickel plated
13	Exhaust filter	Resin	
14	Rod seal	NBR	
15	Piston seal	NBR	
16	Gasket	NBR	
17	Gasket	NBR	

Replacement Parts

Description	Kit no.	Main parts	Note
Seal kit	Please contact SMC to replace seal kit		

Replacement part/Grease pack part no.: GR-S-005 (5 g)

Dimensions

MHC2-6□

4 x M2 x 0.4 through
Thread for attachment
mounting

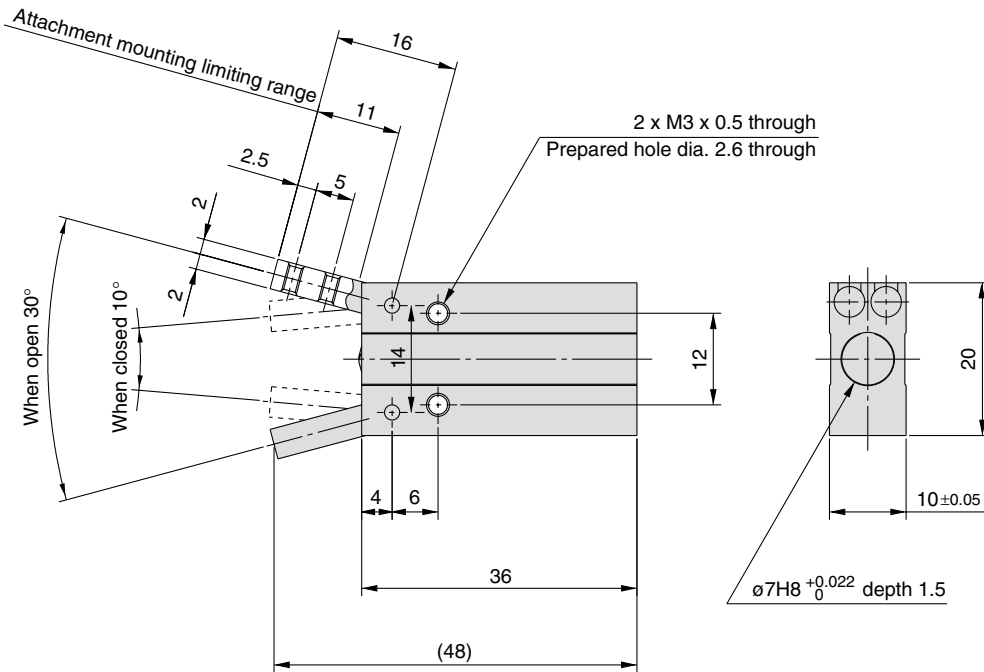
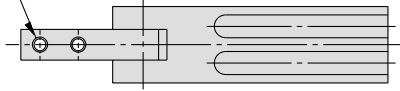

Auto switch mounting groove dimensions

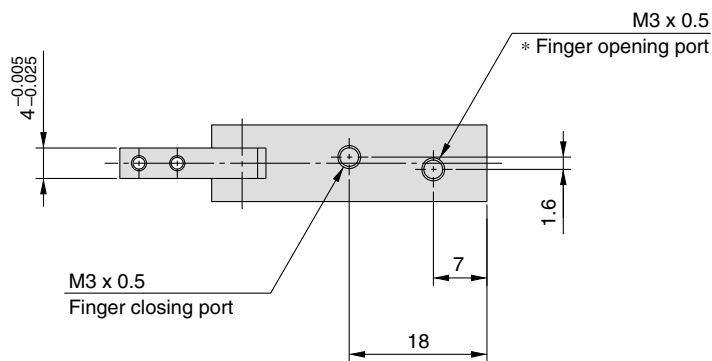

* In the case of MHC2-6S, finger opening port is a breathing hole.

MHZ

MHF

MHL

MHR

MHK

MHS

MHC

MHT

MHY

MHW

-X□

MRHQ

MA

D-□

Series MHC2-6/MHCA2-6

Dimensions

MHCA2-6□ (Short body type)

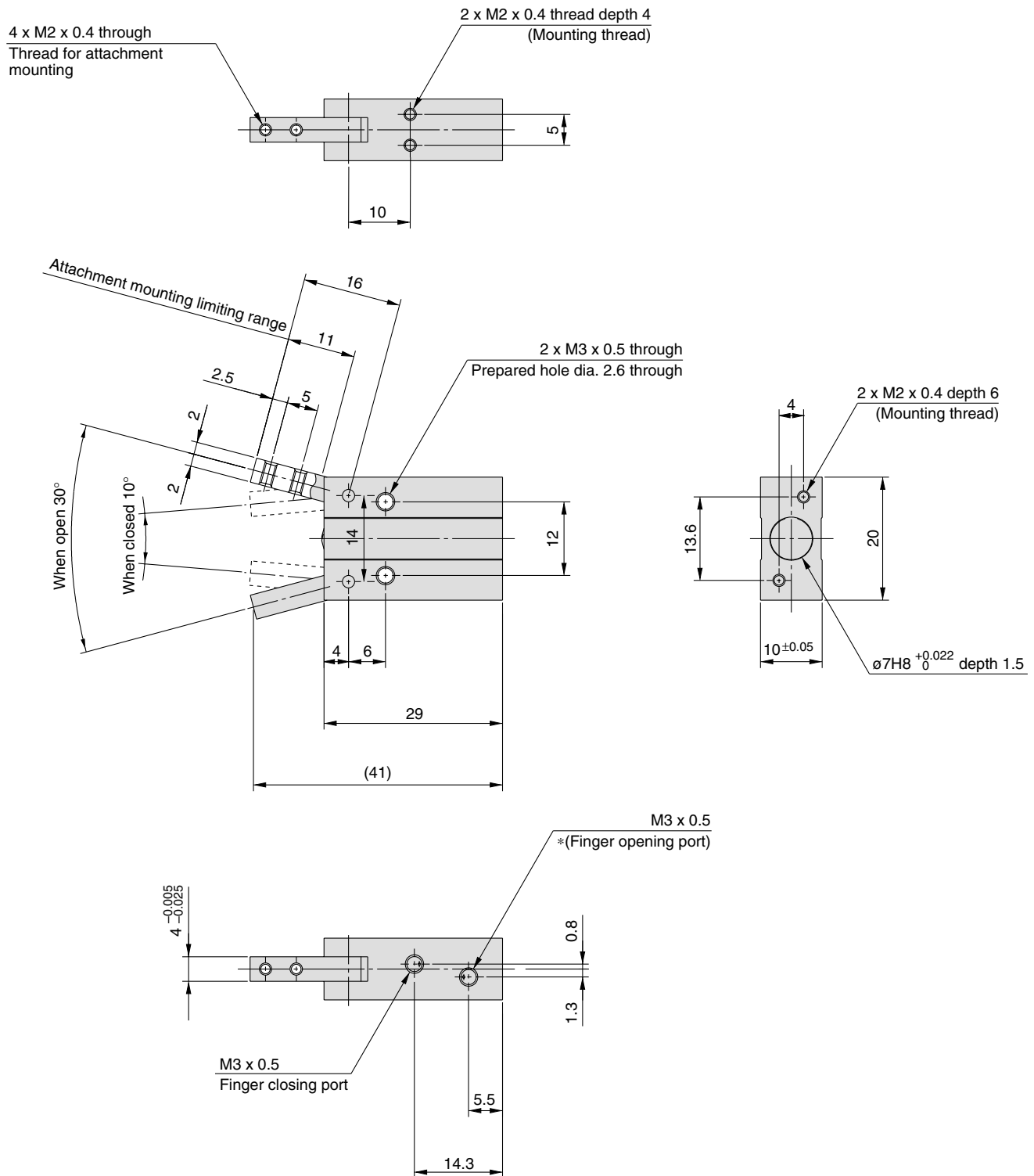

* In the case of MHCA2-6S, finger opening port is a breathing hole.

Series MHCA2

Body Option: End Boss Type

Applicable Model

Symbol	Piping port location	Type of piping port	Applicable model	
			Double acting	Single acting
E	Side ported	M3 x 0.5	●	●
H	Axial ported	With ø4 hose nipple	—	●
K		With ø4 One-touch fitting	—	●
M		M3 x 0.5	—	●

Side Ported [E]

MHCA2-6□E

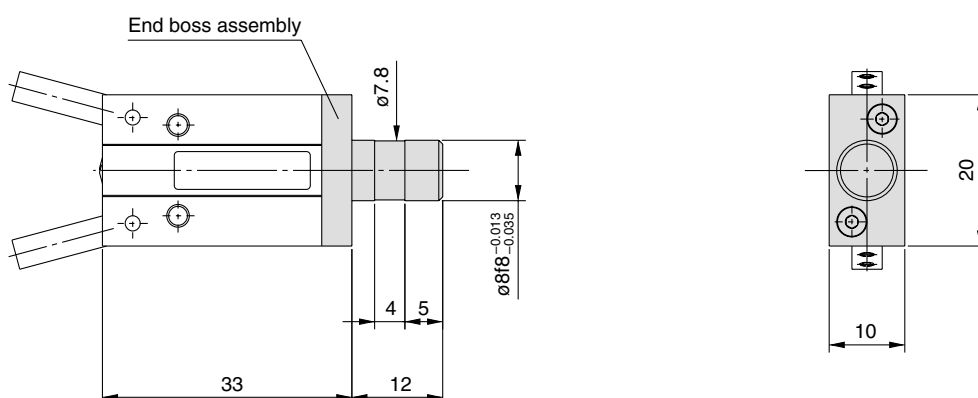

* The specifications and dimensions not given above are identical with those of the standard type.

Axial Ported (With hose nipple) [H]

MHCA2-6SH

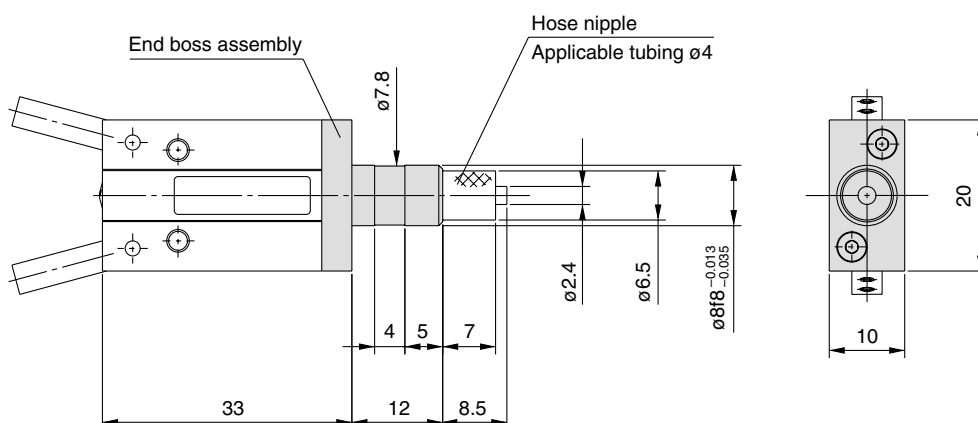

* The specifications and dimensions not given above are identical with those of the standard type.

Applicable Tubing

Description/Model	Nylon tubing	Soft nylon tubing	Polyurethane tubing	Polyurethane coil tubing
	T0425	TS0425	TU0425	TCU0425B-1
Specifications				
Outside diameter mm	4	4	4	4
Max. operating pressure MPa	1.0	0.8	0.5	0.5
Min. bending radius mm	13	12	10	—
Operating temperature °C	-20 to 60	-20 to 60	-20 to 60	-20 to 60
Material	Nylon 12	Nylon 12	Polyurethane	Polyurethane

Refer to "Best Pneumatics No. 6" regarding One-touch fittings and tubing.

MHZ

MHF

MHL

MHR

MHK

MHS

MHC

MHT

MHY

MHW

-X□

MRHQ

MA

D-□

Series MHC2-6/MHCA2-6

Axial Ported (With One-touch fitting) [K]

MHCA2-6SK

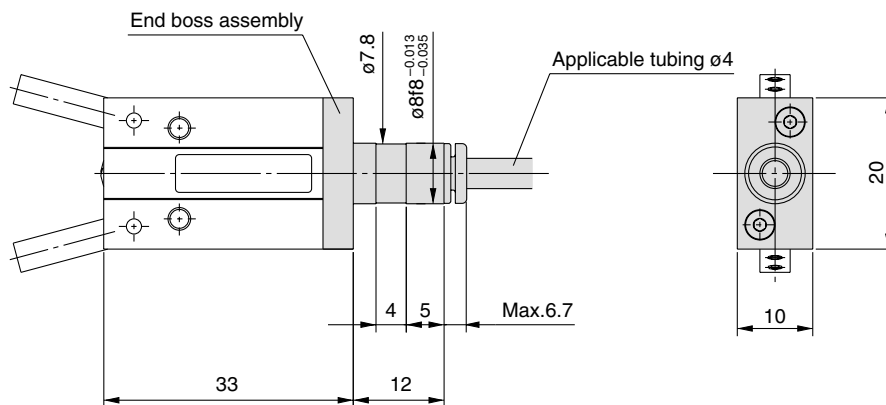

* The specifications and dimensions not given above are identical with those of the standard type.

Applicable Tubing

Description/Model	Nylon tubing	Soft nylon tubing	Polyurethane tubing	Polyurethane coil tubing
Specifications	T0425	TS0425	TU0425	TCU0425B-1
Outside diameter mm	4	4	4	4
Max. operating pressure MPa	1.0	0.8	0.5	0.5
Min. bending radius mm	13	12	10	—
Operating temperature °C	-20 to 60	-20 to 60	-20 to 60	-20 to 60
Material	Nylon12	Nylon12	Polyurethane	Polyurethane

Refer to "Best Pneumatics No. 6" regarding One-touch fittings and tubing.

Axial Ported (With M3 port) [M]

MHCA2-6SM

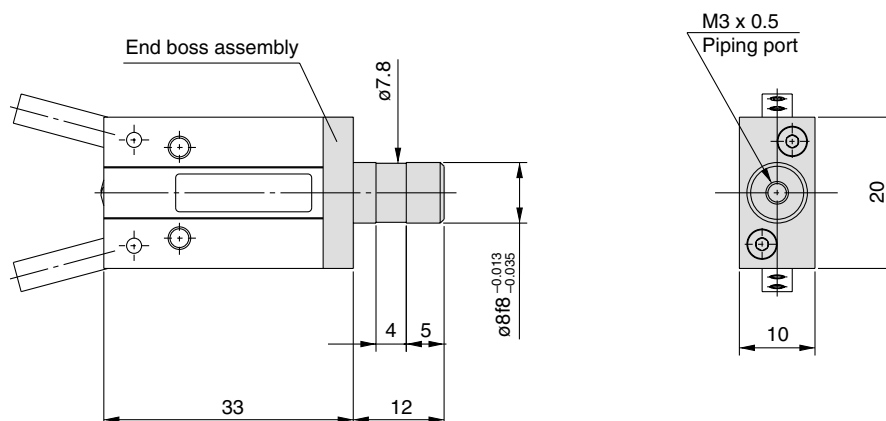

* The specifications and dimensions not given above are identical with those of the standard type.

Mass

Unit: g

Model	End boss type (Symbol)			
	E	H	K	M
MHCA2-6□□	23	23	23	23

Series MHC2-6/MHCA2-6 Auto Switch Installation Examples and Mounting Positions

Various auto switch applications are possible through different combinations of auto switch quantities and detecting positions.

1) Detection when Gripping Exterior of Workpiece

Detection example		1. Confirmation of fingers in reset position	2. Confirmation of workpiece held	3. Confirmation of workpiece released	
Position to be detected		Position of fingers fully opened	Position when gripping workpiece	Position of fingers fully closed	
Operation of auto switch		Auto switch turned on when fingers return. (Light ON)	Auto switch turned on when gripping a workpiece. (Light ON)	When a workpiece is held (Normal operation): Auto switch to turn OFF (Light not illuminating) When a workpiece is not held (Abnormal operation): Auto switch to turn ON (Light illuminating)	
Detection combinations	One auto switch	●	●	●	
	Two auto switches	●—●	●—●	●—●	
How to determine auto switch installation position		Step 1) Fully open the fingers.	Step 1) Position fingers for gripping a workpiece.	Step 1) Position fingers for gripping a workpiece.	
At no pressure or low pressure, connect the auto switch to a power supply, and follow the directions.		Step 2) Insert the auto switch into the auto switch installation groove in the direction shown in the drawing.			
		Step 3) Slide the auto switch in the direction of the arrow until the indicator light illuminates.	Step 3) Slide the auto switch in the direction of the arrow until the light illuminates and fasten it at a position 0.3 to 0.5 mm in the direction of the arrow beyond the position where the indicator light illuminates.	Position where light turns ON	
		Step 4) Slide the auto switch further in the direction of the arrow until the indicator light goes out.	0.3 to 0.5 mm		
		Step 5) Move the auto switch in the opposite direction and fasten it at a position 0.3 to 0.5 mm beyond the position where the indicator light illuminates.	Position to be secured		
		Position where light turns ON		Fitting position 0.3 to 0.5 mm	



Note 1) It is recommended that gripping of a workpiece be performed close to the center of the finger stroke.

Note 2) When holding a workpiece close at the end of open/close stroke of fingers, detecting performance of the combinations listed in the above table may be limited, depending on the hysteresis of an auto switch, etc.

MHZ

MHF

MHL

MHR

MHK

MHS

MHC

MHT

MHY

MHW

-X□

MRHQ

MA

D-□

Series MHC2-6/MHCA2-6

Auto Switch Hysteresis

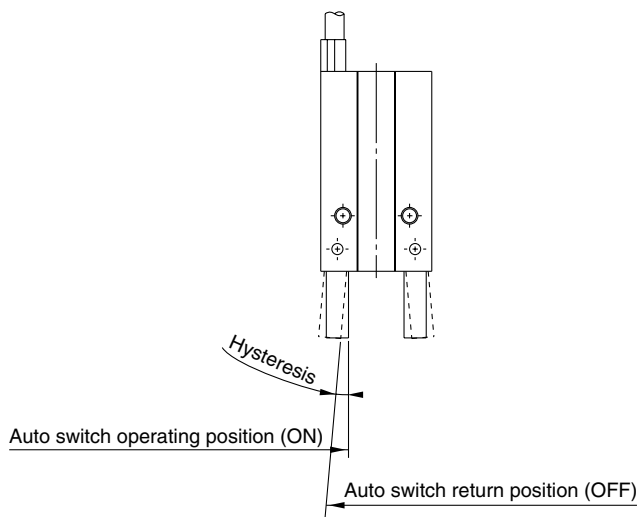

Hysteresis

Model	D-M9□(V)
MHC2-6□	4°

Auto Switch Mounting

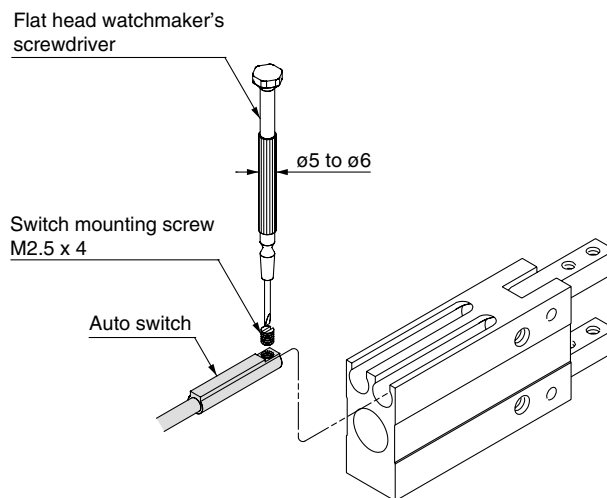

Note) Use a watchmaker's screwdriver with a grip diameter of 5 to 6 mm to tighten the auto switch mounting screw. The tightening torque should be about 0.05 to 0.15 N·m.

Protrusion of Auto Switch from Edge of Body

- The amount of auto switch protrusion from the body end surface is shown in the table below.
- Use this as a standard when mounting, etc.

		Lead wire type	In-line entry	Perpendicular entry
Air gripper model	MHC2-6□	Illustration		
		Auto switch model	D-M9□	D-M9□V
		Finger position		
		Open	6.5 mm	4.5 mm
		Close	9 mm	7 mm

Angular Style Air Gripper Compact Type

Series *MHCM2-7S*

How to Order

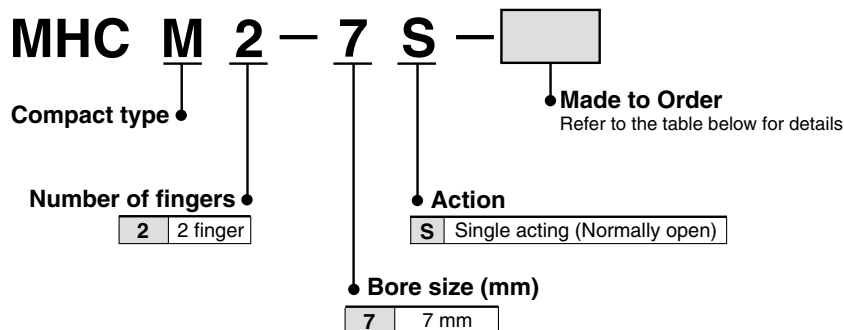

JIS Symbol

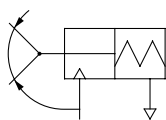

Specifications

Fluid	Air
Operating pressure	0.4 to 0.6 MPa
Ambient and fluid temperature	-10 to 60°C
Repeatability	±0.02 mm
Maximum operating frequency	180 c.p.m.
Lubrication	Non-lube
Action	Single acting (Normally open)

Model

Action	Model	Cylinder bore (mm)	Gripping moment ^{Note)} (Effective value) N·m	Opening/Closing angle (Both sides)	Mass (g)
Single acting (Normally open)	MHCM2-7S	7	0.017	20° to -7°	9.5

Note) At the pressure of 0.5 MPa



Made to Order
Refer to pages 683 to 713 for details.

Symbol	Specifications/Description
-X4	Heat resistance (100°C)
-X5	Fluororubber seal
-X56	Axial piping type
-X63	Fluorine grease
-X79	Grease for food

MHZ

MHF

MHL

MHR

MHK

MHS

MHC

MHT

MHY

MHW

-X□

MRHQ

MA

D-□

Series MHCM2-7S

Construction/MHCM2-7S (Compact type)

Single acting/With fingers open

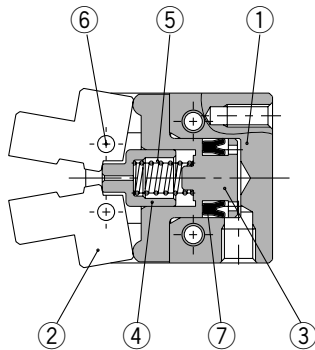

With fingers closed

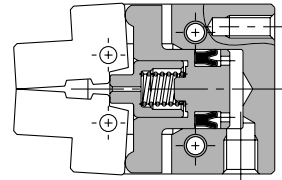

Component Parts

No.	Description	Material	Note	Replacement parts order no.
1	Body	Aluminium alloy	Hard anodized	
2	Finger	Stainless steel	Heat treatment	
3	Piston	Stainless steel	Heat treatment	
4	Pusher	Stainless steel		
5	Spring	Piano wire	Zinc chromated	
6	Needle roller	High carbon chromium bearing steel		
7	Piston seal	NBR		MYN-4

Dimensions

MHCM2-7S

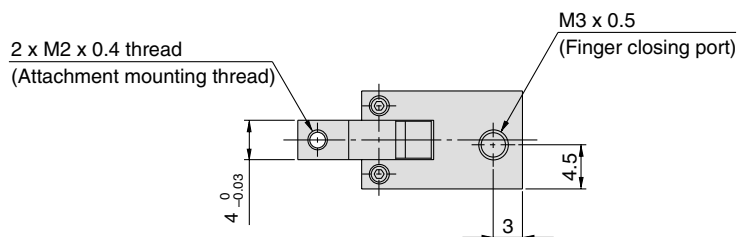
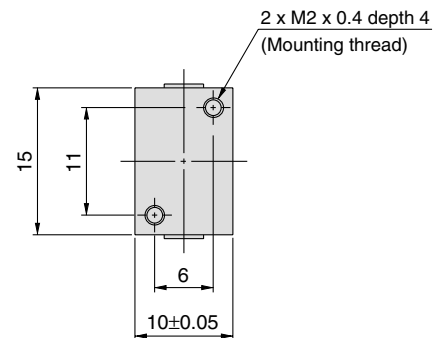
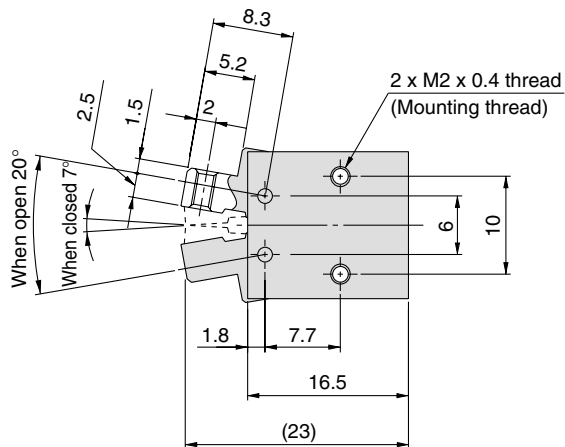

Angular Style Air Gripper/Standard Type Series **MHC2**

How to Order

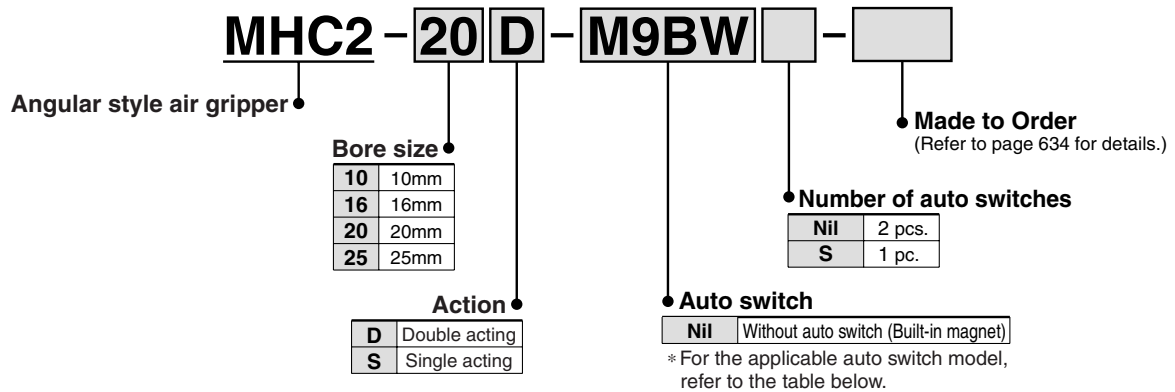

Applicable Auto Switch/Refer to pages 761 to 809 for further information on auto switches.

Type	Special function	Electrical entry	Indicator light	Wiring (Output)	Load voltage		Auto switch model		Lead wire length (m)*				Pre-wired connector	Applicable load		
					DC	AC	Electrical entry direction		0.5 (Nil)	1 (M)	3 (L)	5 (Z)		IC circuit	Relay, PLC	
							Perpendicular	In-line								
Solid state switch	Diagnosis (2-color indication)	Grommet	Yes	3-wire (NPN)	24 V	5 V, 12 V	—	M9NV	M9N	●	●	●	○	○	IC circuit	—
				3-wire (PNP)				M9PV	M9P	●	●	●	○	○		
				2-wire				M9BV	M9B	●	●	●	○	○		
				3-wire (NPN)				M9NVV	M9NV	●	●	●	○	○		
				3-wire (PNP)				M9PVV	M9PV	●	●	●	○	○		
				2-wire				M9BVV	M9BV	●	●	●	○	○		

* Lead wire length symbols: 0.5 m..... Nil (Example) M9NW
 1 m..... M (Example) M9NWM
 3 m..... L (Example) M9NWL
 5 m..... Z (Example) M9NWZ

* Solid state auto switches marked with a "○" symbol are produced upon receipt of order.

Note 1) Take note of hysteresis with 2-color indication type switches. Refer to "Auto Switch Hysteresis" on page 640.
 Note 2) Refer to pages 761 to 809 for further information on auto switches.

MHZ

MHF

MHL

MHR

MHK

MHS

MHC

MHT

MHY

MHW

-X□

MRHQ

MA

D-□

Series MHC2

- A large amount of gripping force is provided through the use of a double piston mechanism, while maintaining a compact design.
- Built-in variable throttle
- A solid state auto switch with an indicator light can be mounted.

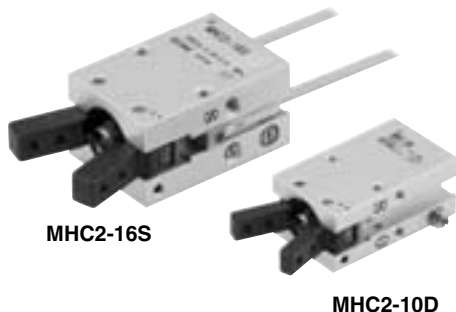

JIS Symbol

Double acting

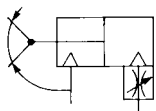

Single acting

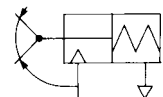

Made to Order

(Refer to page 683 to 713 for details.)

Symbol	Specifications/Description
-X4	Heat resistance (100°C)
-X5	Fluororubber seal
-X50	Without magnet
-X53	EPDM seal/Fluorine grease
-X56	Axial Ported
-X63	Fluorine grease
-X64	Finger: Side tapped mounting
-X65	Finger: Through-hole mounting
-X79	Grease for food

Specifications

Fluid		Air
Operating pressure	Double acting	0.1 to 0.6 MPa
	Single acting	0.25 to 0.6 MPa
Ambient and fluid temperature		-10 to 60°C
Repeatability		±0.01 mm
Max. operating frequency		180 c.p.m
Lubrication		Not required
Action		Double acting, Single acting
Auto switch (Option) <small>Note</small>		Solid state auto switch (3-wire, 2-wire)



Note) Refer to pages 761 to 809 for further information on auto switches.

Model

Action	Model	Bore size (mm)	Gripping moment (N·m) (Effective value) ⁽¹⁾	Opening/closing angle (Both sides)	Mass ⁽²⁾ (g)
Double acting	MHC2-10D	10	0.10	30° to -10°	39
	MHC2-16D	16	0.39		91
	MHC2-20D	20	0.70		180
	MHC2-25D	25	1.36		311
Single acting	MHC2-10S	10	0.070	30° to -10°	39
	MHC2-16S	16	0.31		92
	MHC2-20S	20	0.54		183
	MHC2-25S	25	1.08		316



Note 1) At the pressure of 0.5 MPa.

Refer to "Effective Gripping Force" data on page 635 for gripping force of each gripping point.

Note 2) Except auto switch.

Gripping Point

- Workpiece gripping point should be within the range indicated in the graph.

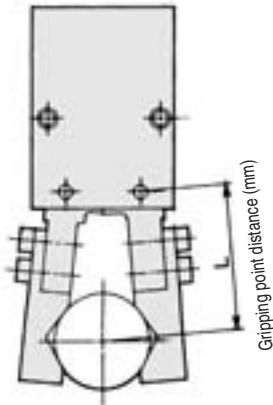

Guidelines for the selection of the gripper with respect to component weight

- Although conditions differ according to the workpiece shape and the coefficient of friction between the attachments and the workpiece, select a model that can provide a gripping force of 10 to 20 times the workpiece weight, or more.
- If high acceleration, deceleration or impact forces are encountered during motion, a further margin of safety should be considered.

● Indication of effective gripping force

The effective gripping force shown in the graphs below is expressed as F , which is the thrust of one finger, when both fingers and attachments are in full contact with the workpiece as shown in the figure below.

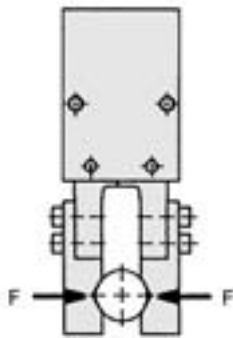

Effective Gripping Force

Double Acting

MHC2-10D

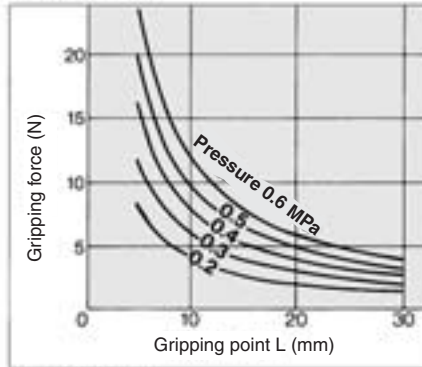

MHC2-16D

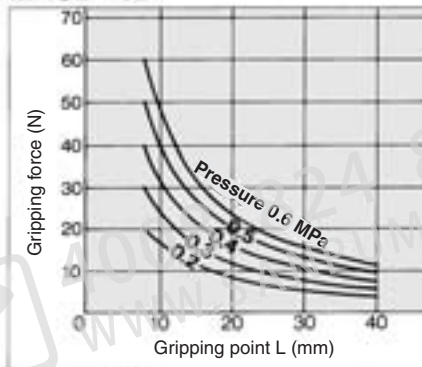

MHC2-20D

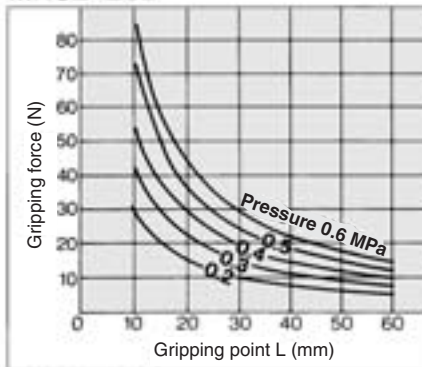

MHC2-25D

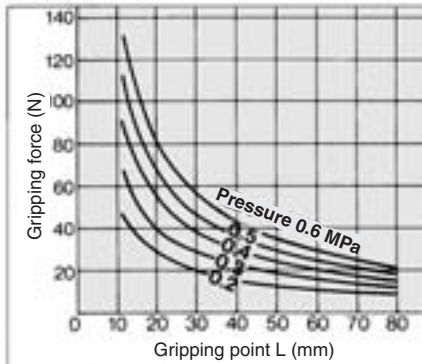

Single Acting

MHC2-10S

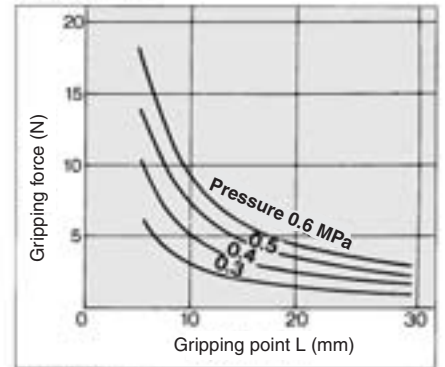

MHC2-16S

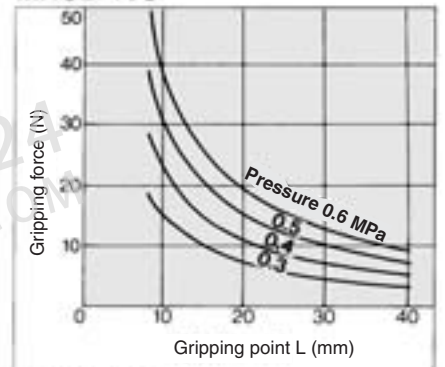

MHC2-20S

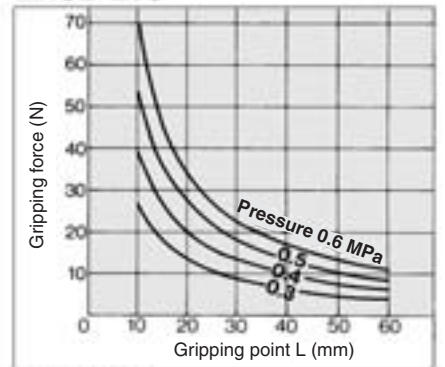

MHC2-25S

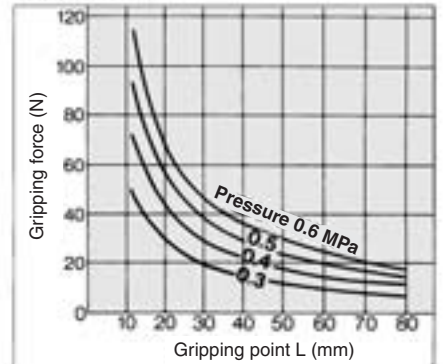

MHZ

MHF

MHL

MHR

MHK

MHS

MHC

MHT

MHY

MHW

-X

MRHQ

MA

D-

Series MHC2

Construction

Double acting/With fingers open

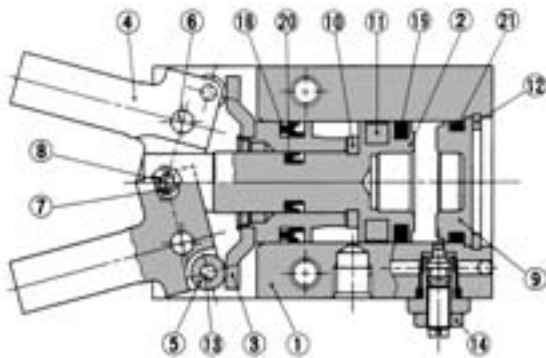

Single acting

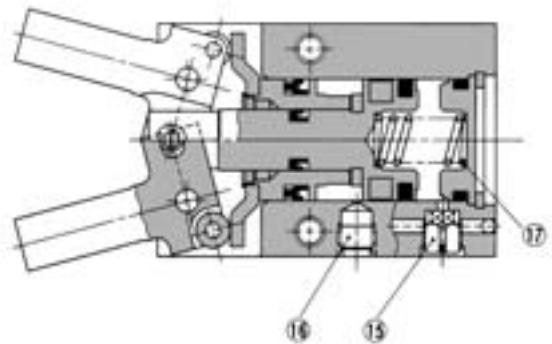

Double acting/With fingers closed

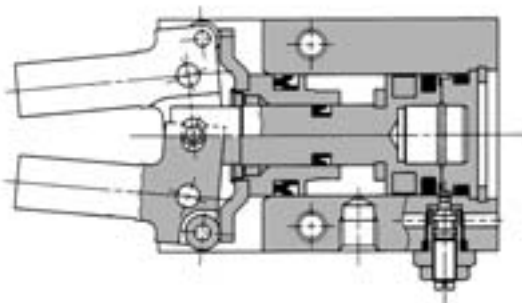

With auto switch

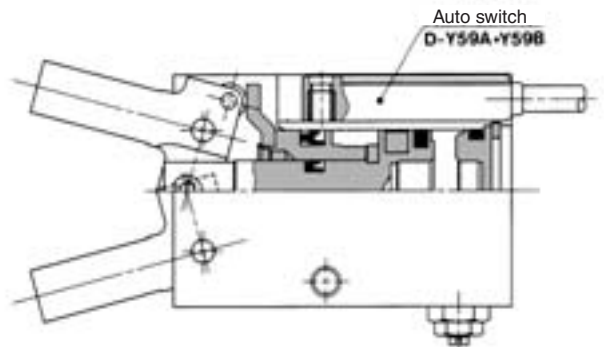

Component Parts

No.	Description	Material	Note
1	Body	Aluminum alloy	Hard anodized
2	Piston A	Aluminum alloy	Hard anodized
3	Piston B assembly		
4	Finger	Carbon steel	Heat treated
5	Side roller	Carbon steel	Nitriding
6	Lever shaft	Stainless steel	Nitriding
7	Center roller	Carbon steel	Nitriding
8	Center pin	Carbon steel	Nitriding
9	Cap	Resin	
10	Bumper	Urethane rubber	
11	Rubber magnet	Synthetic rubber	

Component Parts

No.	Description	Material	Note
12	Type C retaining ring	Carbon steel	Nickel plated
13	Needle roller	High carbon chrome bearing steel	
14	Needle assembly	Brass	Electroless nickel plated
15	Exhaust plug	Brass	Electroless nickel plated
16	Plug	Brass	Electroless nickel plated
17	Spring	Stainless steel spring wire	
18	Piston seal	NBR	
19	Piston seal	NBR	
20	Piston seal	NBR	
21	Gasket	NBR	

Replacement Parts

Description	MHC2-10□	MHC2-16□	MHC2-20□	MHC2-25□	Main parts
Seal kit	MHC10-PS	MHC16-PS	MHC20-PS	MHC25-PS	18 19 20 21
Finger assembly	MHC-A1003	MHC-A1603	MHC-A2003	MHC-A2503	4 5 6 7 8 13
Piston assembly set	MHC-A1002	MHC-A1602	MHC-A2002	MHC-A2502	2 3 7 8 10 11 18 19 20
Piston A assembly	MHC-A1001	MHC-A1601	MHC-A2001	MHC-A2501	2 10 11
Piston B assembly	P3311145B	P3311245B	P3311345B	P3311445C	3
Needle assembly	MH-A1006		MH-A1606		14

* Order 1 piece finger assembly per one unit.

Replacement part/Grease pack part no.: GR-S-005 (5g)



Double Acting: Size 10, 16

MHC2-10□

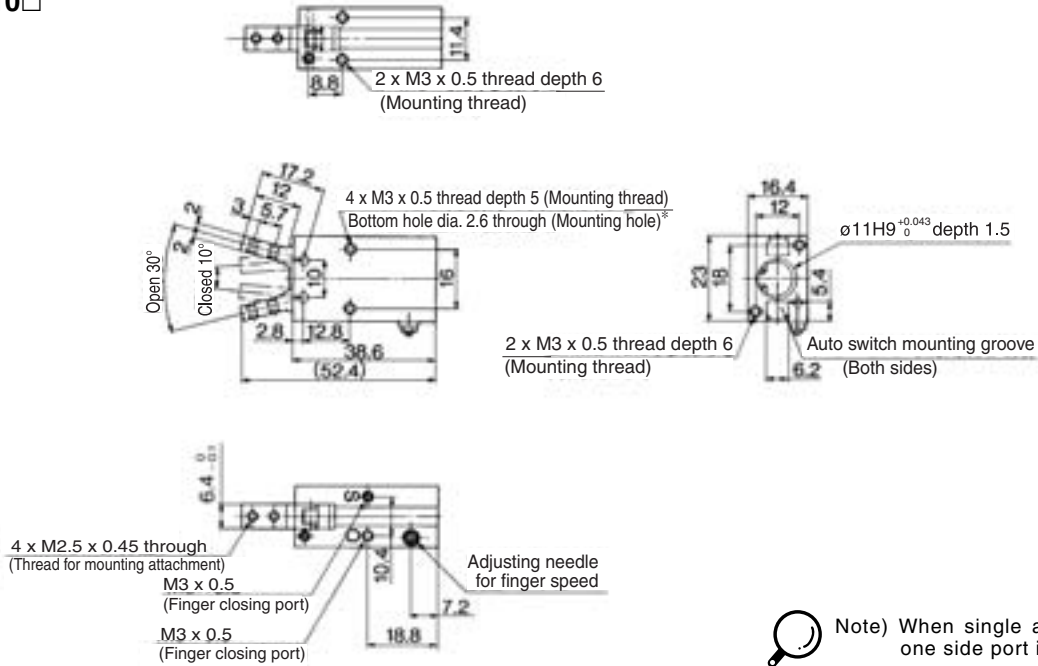

Note) When single acting type is used, one side port is breath port.

* When auto switches are used, through hole mounting is not available.

MHC2-16□

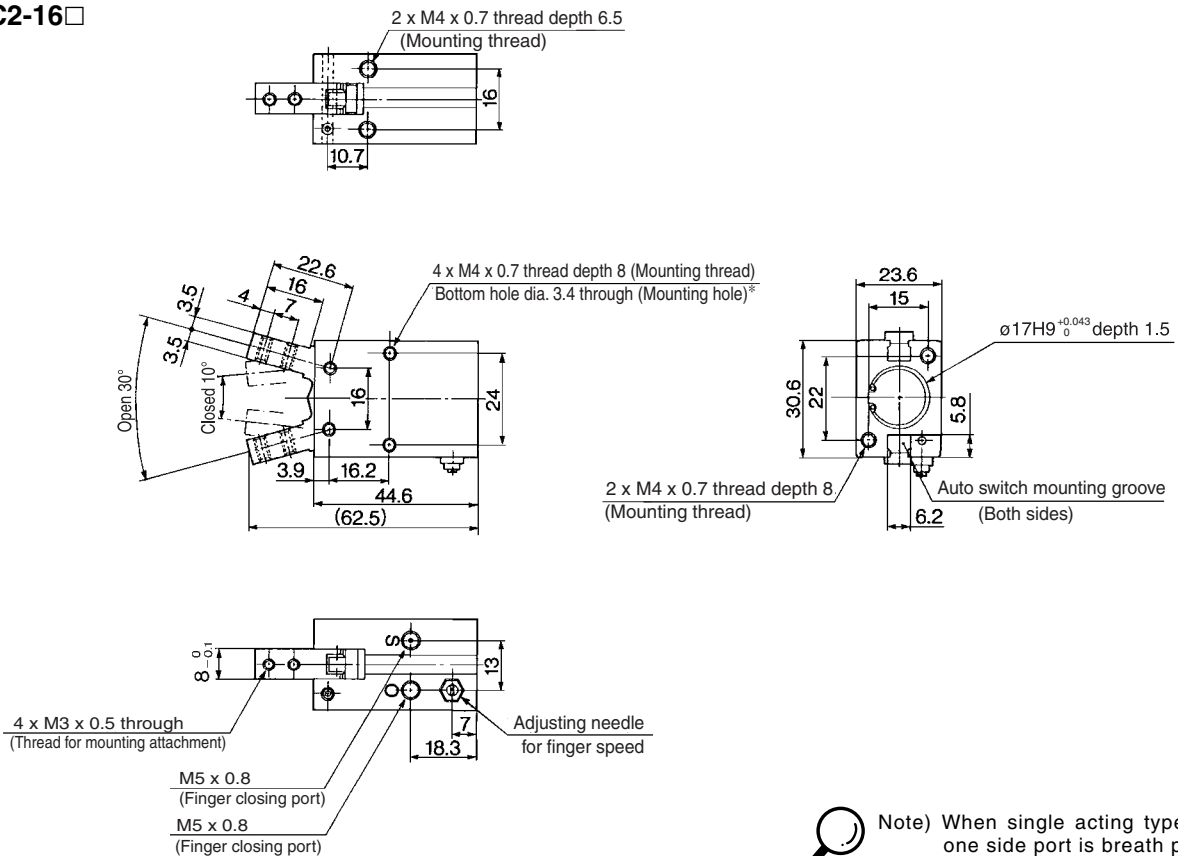

Note) When single acting type is used, one side port is breath port.

* When auto switches are used, through hole mounting is not available.

MHZ

MHF

MHL

MHR

MHK

MHS

MHC

MHT

MHY

MHW

-X□

MRHQ

MA

D-□

Series MHC2

Double Acting: Size 20, 25

MHC2-20

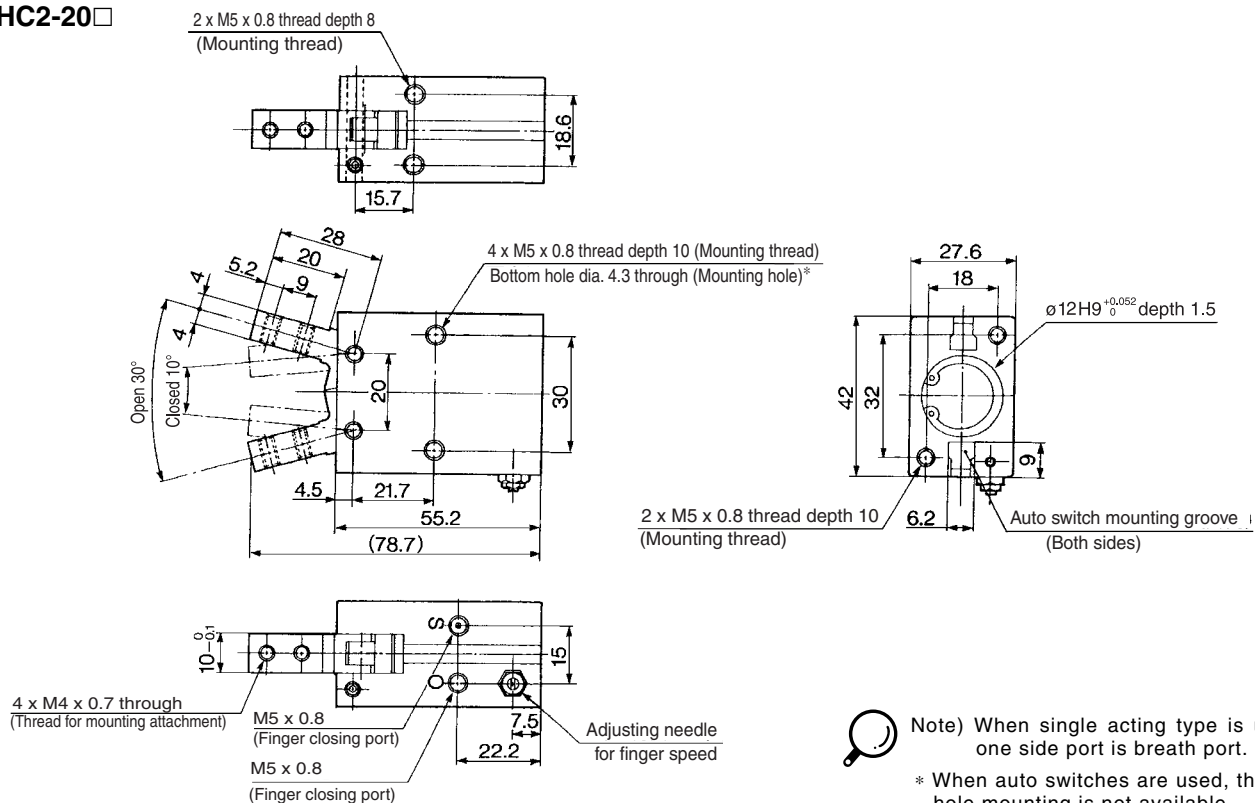

Note) When single acting type is used, one side port is breath port.
* When auto switches are used, through hole mounting is not available.

MHC2-25

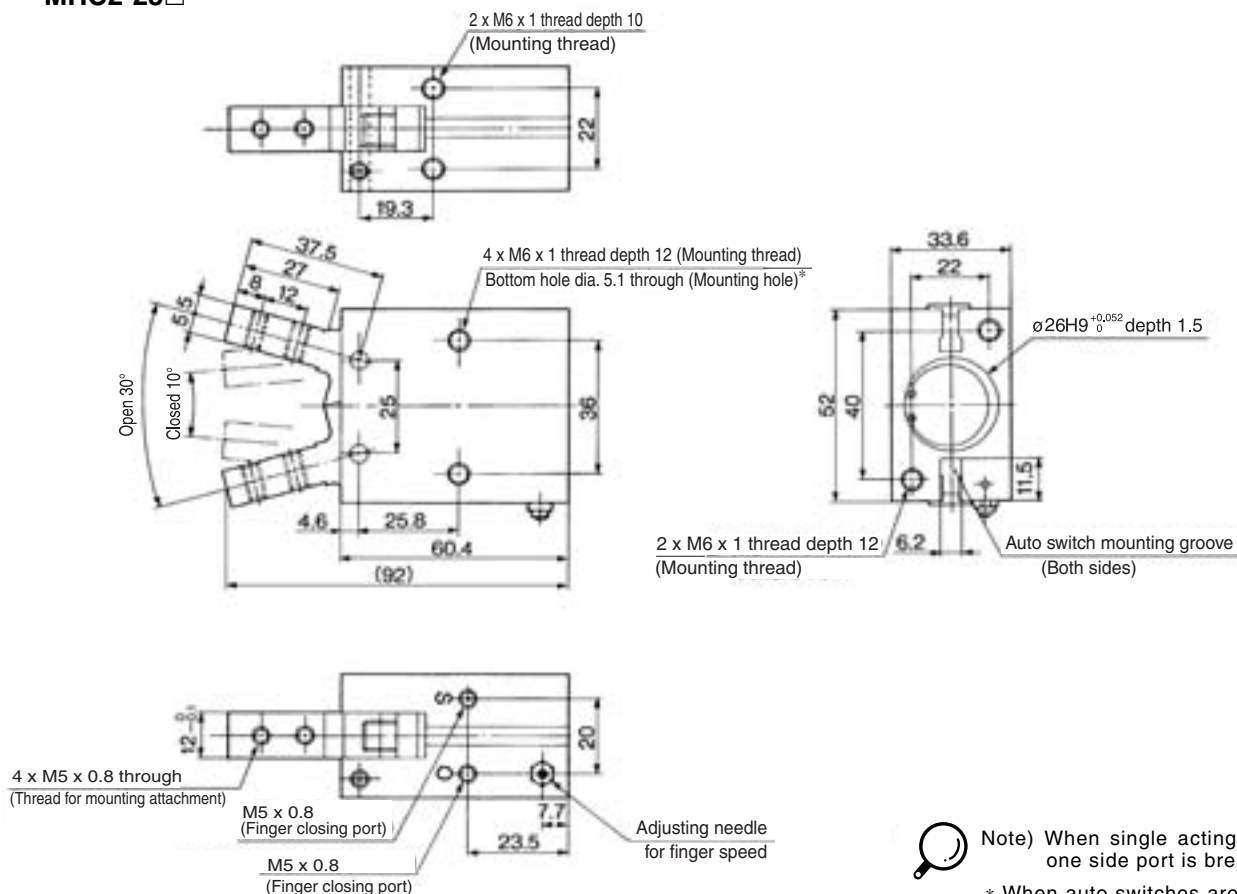

Note) When single acting type is used, one side port is breath port.
* When auto switches are used, through hole mounting is not available.

Series MHC2

Auto Switch Installation Examples and Mounting Positions

Various auto switch applications are possible through different combinations of auto switch quantities and detecting positions.

Detection when Gripping Exterior of Workpiece

Detection example		1. Confirmation of fingers in reset position	2. Confirmation of workpiece held	3. Confirmation of workpiece released	
Position to be detected		Position of fingers fully opened	Position when gripping a workpiece	Position of fingers fully closed	
Operation of auto switch		Auto switch turned ON when fingers return. (Light ON)	Auto switch turned ON when gripping a workpiece. (Light ON)	When a workpiece is held (Normal operation): Auto switch to turn OFF (Light not illuminating) When a workpiece is not held (Abnormal operation): Auto switch to turn ON (Light illuminating)	
Detection combinations	One auto switch	●	●	●	
	Two auto switches	●—●	●—●	●—●	
		●—●	●—●	●—●	
How to determine auto switch installation position		Step 1) Fully open the fingers.	Step 1) Position fingers for gripping a workpiece.	Step 1) Position fingers for gripping a workpiece.	
At no pressure or low pressure, connect the auto switch to a power supply, and follow the directions.		Step 2) Insert the auto switch into the auto switch installation groove in the direction shown in the following drawing.			
		Step 3) Slide the auto switch in the direction of the arrow until the indicator light illuminates.	Step 3) Slide the auto switch in the direction of the arrow until the light illuminates and fasten it at a position 0.3 to 0.5 mm in the direction of the arrow beyond the position where the indicator light illuminates.	<p>Position where light turns ON</p>	
		Step 4) Slide the auto switch further in the direction of the arrow until the indicator light goes out.	<p>0.3 to 0.5 mm</p>		
		Step 5) Move the auto switch in the opposite direction and fasten it at a position 0.3 to 0.5 mm beyond the position where the indicator light illuminates.	<p>Position to be secured</p>		
		<p>Position where light turns ON</p> <p>0.3 to 0.5 mm</p> <p>Position to be secured</p>	<p>0.3 to 0.5 mm</p>		

Note 1) It is recommended that gripping of a workpiece be performed close to the center of the finger stroke.

Note 2) When holding a workpiece close at the end of open/close stroke of fingers, detecting performance of the combinations listed in the above table may be limited, depending on the hysteresis of an auto switch, etc.

MHZ

MHF

MHL

MHR

MHK

MHS

MHC

MHT

MHY

MHW

-X□

MRHQ

MA

D-□



Series MHC2

Auto Switch Mounting

- (1) To set the auto switch, insert the auto switch into the installation groove of the cylinder as shown below and set it roughly.
- (2) Insert the auto switch into the auto switch bracket installation groove.
- (3) After confirming the detecting position, tighten the set screws (M2.5) attached to the auto switch and set it.
- (4) Be sure to change the detecting position in the state of (2).

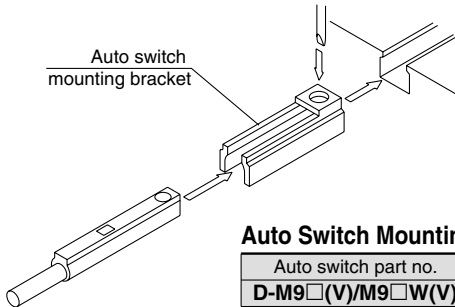

Auto Switch Mounting Bracket: Part No.

Auto switch part no.	Auto switch mounting bracket part no.
D-M9□(V)/M9□W(V)	BMG2-012

Note) Use a screwdriver with a grip diameter of 5 to 6 mm to tighten the set screws (M2.5).

The tightening torque should be 0.05 to 1 N·m.

As a guide, it should be turned about 90° beyond the point at which tightening can be felt.

Handling of Mounting Brackets: Precautions

When auto switch is set on the mounting side as shown below, allow at least 2 mm run off space on mounting late since the auto switch is protruded from the gripper edge.

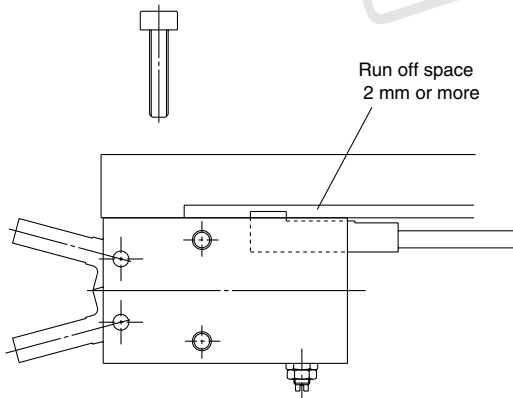

Auto Switch Hysteresis

Auto switches have hysteresis similar to micro switches. Use the table below as a guide when adjusting auto switch positions, etc.

Angular Style

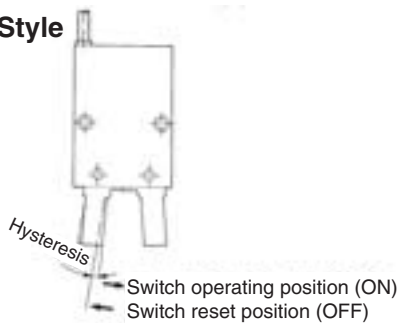

Air gripper model	Hysteresis degree (Max. value)
MHC2-10	4
MHC2-16	3
MHC2-20	2
MHC2-25	2

Protrusion of Auto Switch from Edge of Body

The maximum protrusion of an auto switch (when fingers are fully closed) from the edge of the body is shown in the table below.

Angular Style

When auto switch
D-M9□/M9□W/Y59□/Y7P/Y7□W
is used

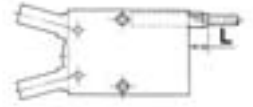

When auto switch
D-M9□V/M9□WV/Y69□/Y7PV/Y7□WV
is used

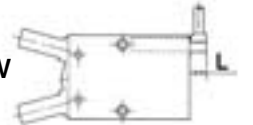

Max. Protrusion of Auto Switch from Edge of Body (L)

Air gripper model	Auto switch model	
	D-Y59□ D-Y7P D-Y7□W	D-Y69□ D-Y7PV D-Y7□WV
MHC2-10	8	6
MHC2-16	7	6
MHC2-20	6	5
MHC2-25	4	3

(mm)

Air gripper model	Auto switch model	
	D-M9□ D-M9□W	D-M9□(V) D-M9□W(V)
MHC2-10	7.5	5.5
MHC2-16	6.5	5.5
MHC2-20	5.5	4.5
MHC2-25	3.5	2.5

(mm)

Note) The actual setting position should be adjusted after confirming the auto switch operating condition.



Series MHC2 Specific Product Precautions

Be sure to read before handling.

Mounting Air Grippers/Series MHC2

Possible to mount from 3 directions.

Axial Mounting (Body tapped)

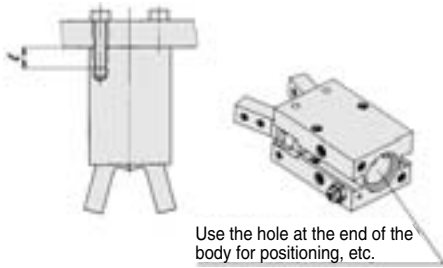

Use the hole at the end of the body for positioning, etc.

Model	Applicable bolts	Max. tightening torque N·m	Max. screw-in depth/mm
MHC2-10	M3 x 0.5	0.88	6
MHC2-16	M4 x 0.7	2.1	8
MHC2-20	M5 x 0.8	4.3	10
MHC2-25	M6 x 1	7.3	12

Model	Hole size (mm)	Hole depth (mm)
MHC2-10	∅11H9 ^{+0.043} ₀	1.5
MHC2-16	∅17H9 ^{+0.043} ₀	1.5
MHC2-20	∅21H9 ^{+0.052} ₀	1.5
MHC2-25	∅26H9 ^{+0.052} ₀	1.5

Lateral mounting (Body tapped and through-hole)

● Body tapped

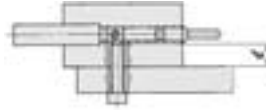

Model	Applicable bolts	Max. tightening torque N·m	Max. screw-in depth/mm
MHC2-10	M3 x 0.5	0.69	5
MHC2-16	M4 x 0.7	2.1	8
MHC2-20	M5 x 0.8	4.3	10
MHC2-25	M6 x 1	7.3	12

● Body through-hole

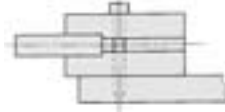

Model	Applicable bolts	Max. tightening torque N·m
MHC2-10	M2.5 x 0.45	0.49
MHC2-16	M3 x 0.5	0.88
MHC2-20	M4 x 0.7	2.1
MHC2-25	M5 x 0.8	4.3

Model	Max. screw-in depth/mm
MHC2-10	5
MHC2-16	8
MHC2-20	10
MHC2-25	12

Note) If an auto switch is to be mounted, only the tapped holes can be used. Make sure that the bolt's screw-in depth is less than those shown in the table on the left to prevent the tip of the bolt from pressing the switch body.

Vertical Mounting (Body tapped)

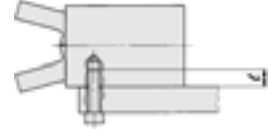

Model	Applicable bolts	Max. tightening torque N·m	Max. screw-in depth/mm
MHC2-10	M3 x 0.5	0.88	6
MHC2-16	M4 x 0.7	1.6	6.5
MHC2-20	M5 x 0.8	3.3	8
MHC2-25	M6 x 1	5.9	10

How to Mount the Attachment to the Finger

To mount the attachment to the finger, make sure to use a wrench to support the attachment so as not to apply undue strain on the finger. Refer to the table below for the proper tightening torque on the bolt used for securing the attachment to the finger.

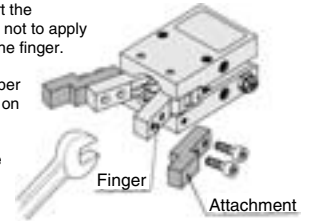

Model	Applicable bolts	Max. tightening torque N·m
MHC2-10	M2.5 x 0.45	0.31
MHC2-16	M3 x 0.5	0.59
MHC2-20	M4 x 0.7	1.4
MHC2-25	M5 x 0.8	2.8

MHZ

MHF

MHL

MHR

MHK

MHS

MHC

MHT

MHY

MHW

-X□

MRHQ

MA

D-□

SANPUM

为高端制造业提供一流的工业产品

SANPUM

深圳市三浦贸易有限公司

地址：深圳市南山区南海大道海王大厦A座19E

电话：86-755-23881000

传真：86-755-23881777

邮箱：info@sanpum.com



4008 824 824
WWW.SANPUM.COM